

**Rugged, high specification luminaire.**

- Ideal for more demanding environments and exterior public spaces
- Die cast aluminium base in black, with polycarbonate opal diffuser
- High frequency control gear
- Shaped diffuser screen option for subtle downlighting/reduced light glare
- Designed and manufactured to meet the requirements of BS EN 60598.2.22



**Luminaire**

Order Code	Input Voltage	Lamp Type	Power Cons. Mains/ Self-contained	Lamp Output Mains/ Self-contained	Operation / Duration (hrs)	Recharge Period	Environment	Weight
MTC28NM	230 - 240 Vac, 50 Hz	28 W 2D	0.2 A / 0.2 A	1800 / 250 lumens	NM3	24 hours	0 - 25 °C	4.3 kg
MTC28M	230 - 240 Vac, 50 Hz	28 W 2D	0.2 A / 0.2 A	1800 / 250 lumens	M3	24 hours	0 - 25 °C	4.8 kg
MTC28PHF	230 - 240 Vac, 50 Hz	28 W 2D	0.2 A / -	1800 / - lumens	230 V	-	0 - 25 °C	3.7 kg

For AC/AC or AC/DC slave luminaires please refer to our EMEX Central Power Supply Systems Catalogue.

**Accessories**



Order Code	Description
MTCD1	Diffuser screen (cross-hair effect)
MTCD2	Diffuser screen (eye effect)



**Dimensions**

Cable entry via 20 mm hole on rear of unit.

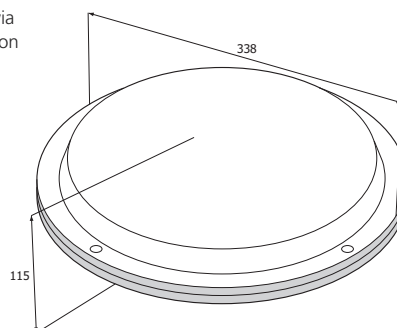

For Hawkeye spacing data, see page 83.  
For further information on Central, IR2 and Self-Test emergency luminaire testing formats, see pages 70 - 74 or contact Emergi-Lite.

ELPC-0410